

PKG Start Date

REV Date

APPROVED

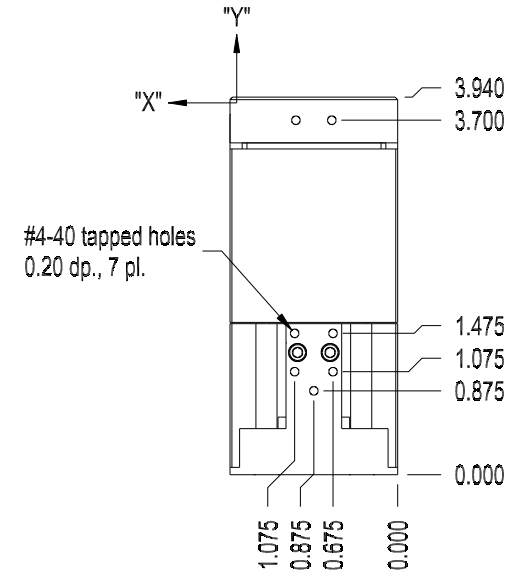
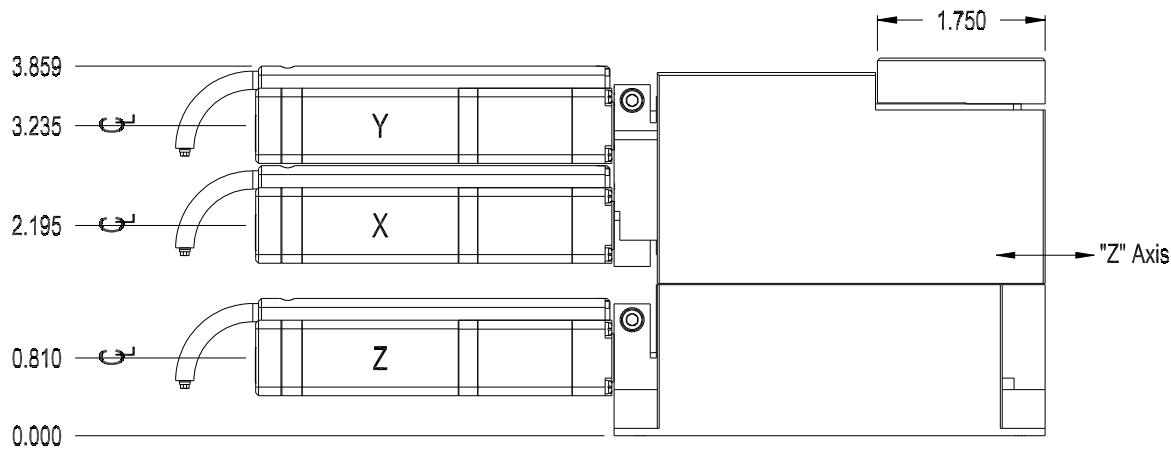
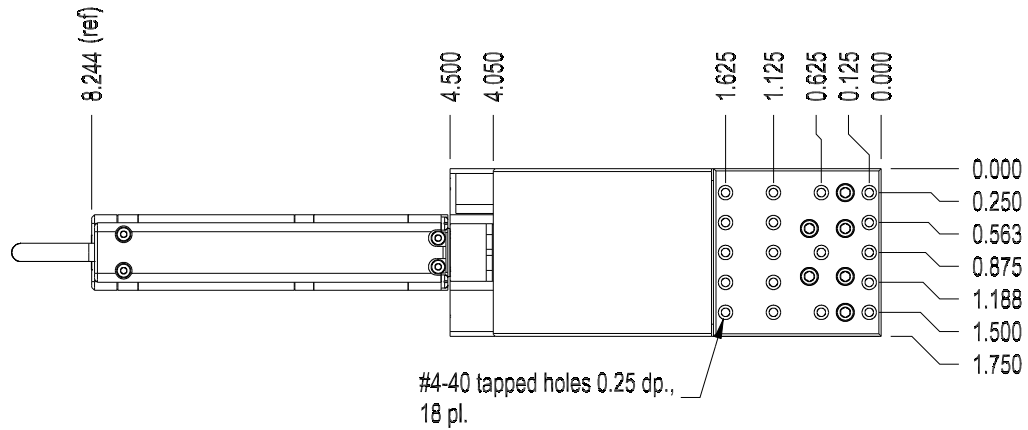

Note: Stage is shown in mid-position of travel  
 Z-Axis travel: +/- 0.250" (6.35mm)  
 X&Y Axis travel: +/- 0.050" (1.27mm)

SKU: U3-H-I



U3 Ultra XYZ Fully Automated Positioner - Outline

Material:	
Finish:	Tolerance:

SIZE A	VIEW:	DWG NO.	PT0080283A	REV A
SCALE 0.5	FILE	PT0080283A.ckd	SHEET 1/3	

PKG Start Date

REV Date

APPROVED

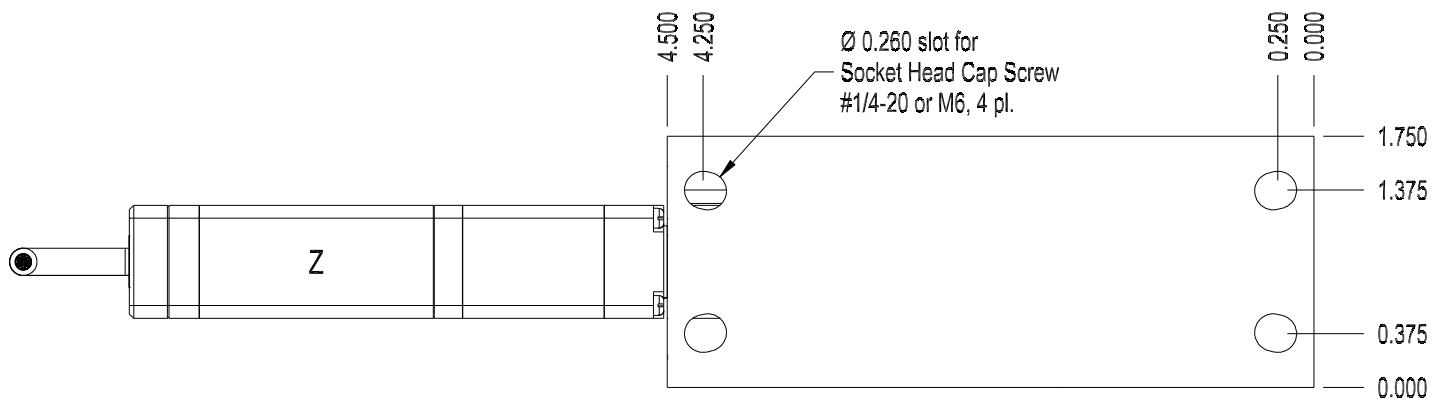

U3 Ultra XYZ Fully Automated Positioner - Bottom Outline

Material:  
Finish: Tolerance:

SIZE A	VIEW: Bot	DWG NO. PT0080283A	REV A
SCALE 0.75	FILE PT0080283A.ckd	SHEET 2/3	

PKG Start Date

REV Date

APPROVED

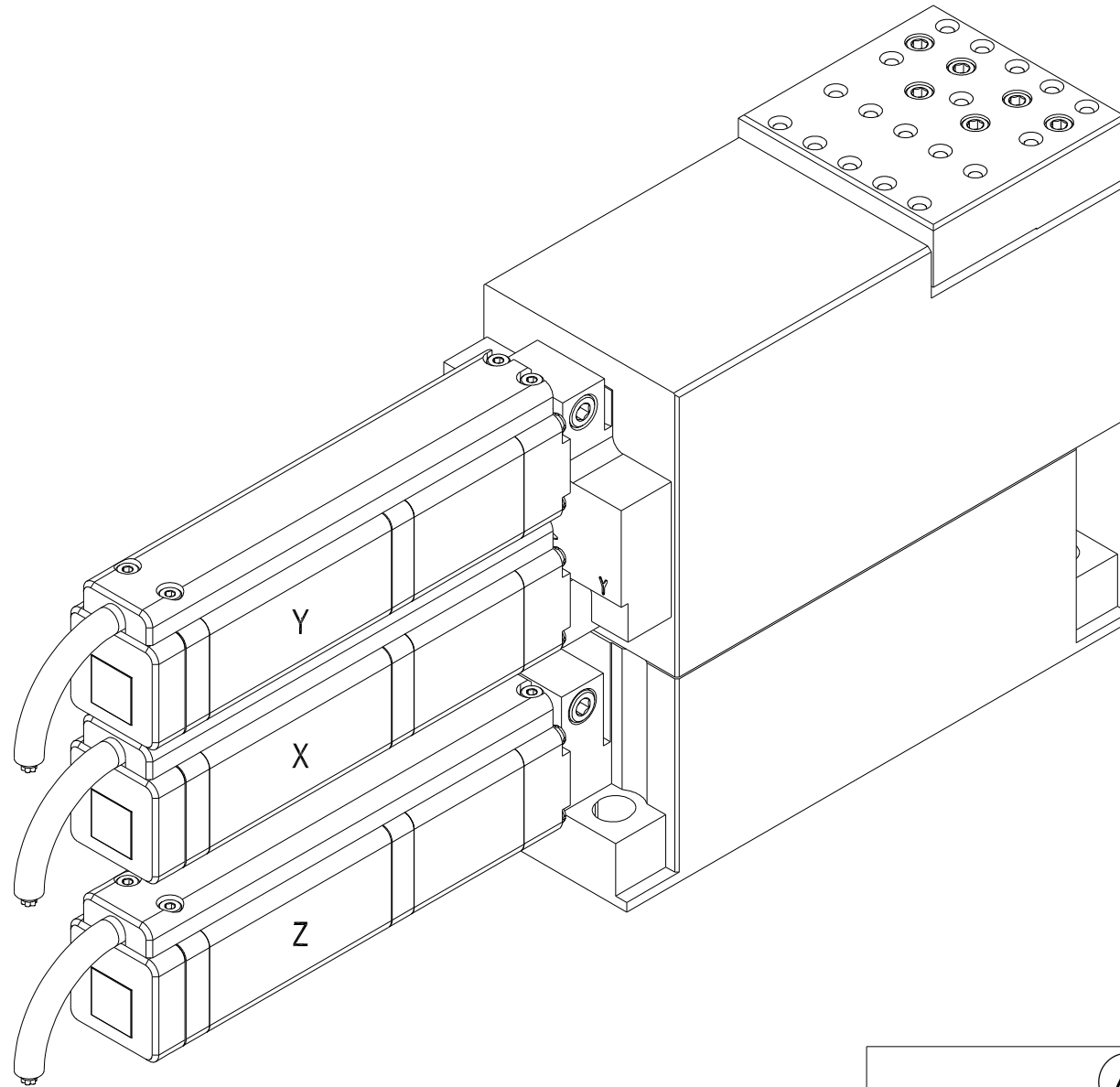

U3 Ultra XYZ Fully Automated Positioner - Perspective View

Material:  
Finish: Tolerance:

SIZE A	VIEW: Iso	DWG NO. PT0080283A	REV A
SCALE 0.9	FILE PT0080283A.ckd	SHEET 3/3	