

NOTE: Stage is shown in mid-position of travel
 Z-Axis travel: ±6.35mm (0.250"), 10um/div.
 X&Y Axis travel: ±1.02mm (0.040") coarse adjustment,
 ±250um (0.010") fine adjustment
 Yaw & Pitch travel: ±1.5°, 30 arc-sec/div., 4 turns/degree

LUMINOS INDUSTRIES LTD				
I5000 XYZYP Positioner (manual) - Front & End Outline				
SIZE A	VIEW	DWG NO.	PT048513A	REV A
SCALE 0.75	FILE	PT0485A.ckd	SHEET 1/3	

Material:	
Finish:	Tolerance:

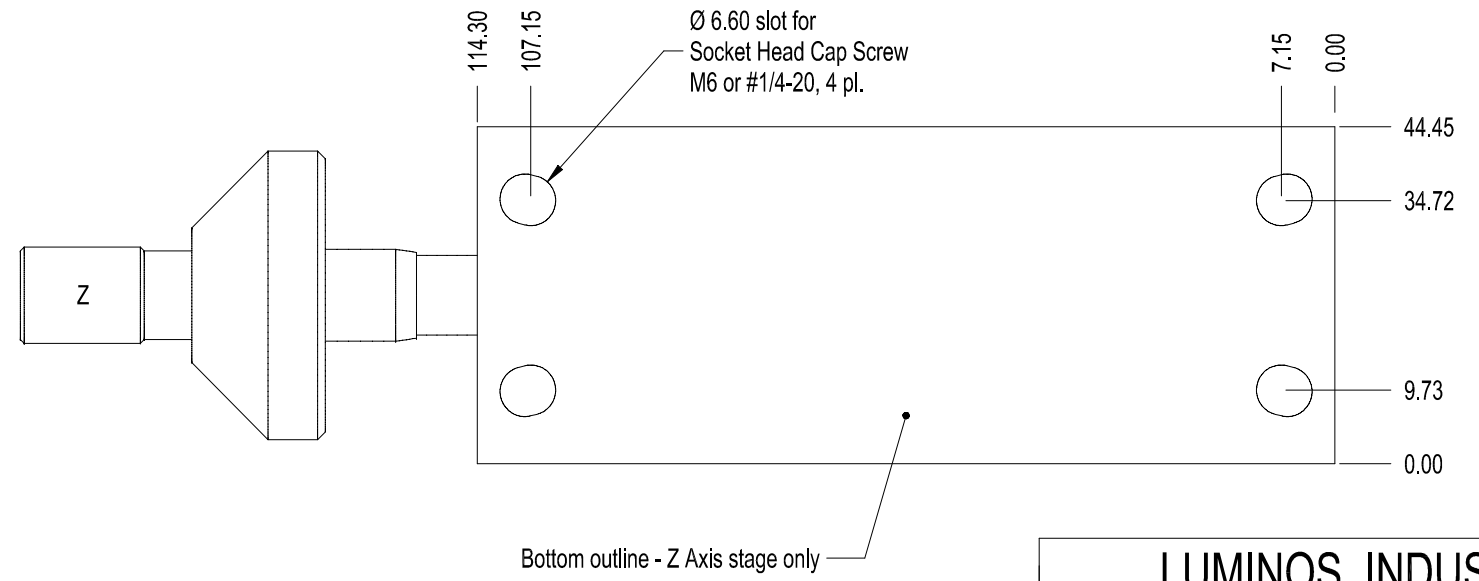
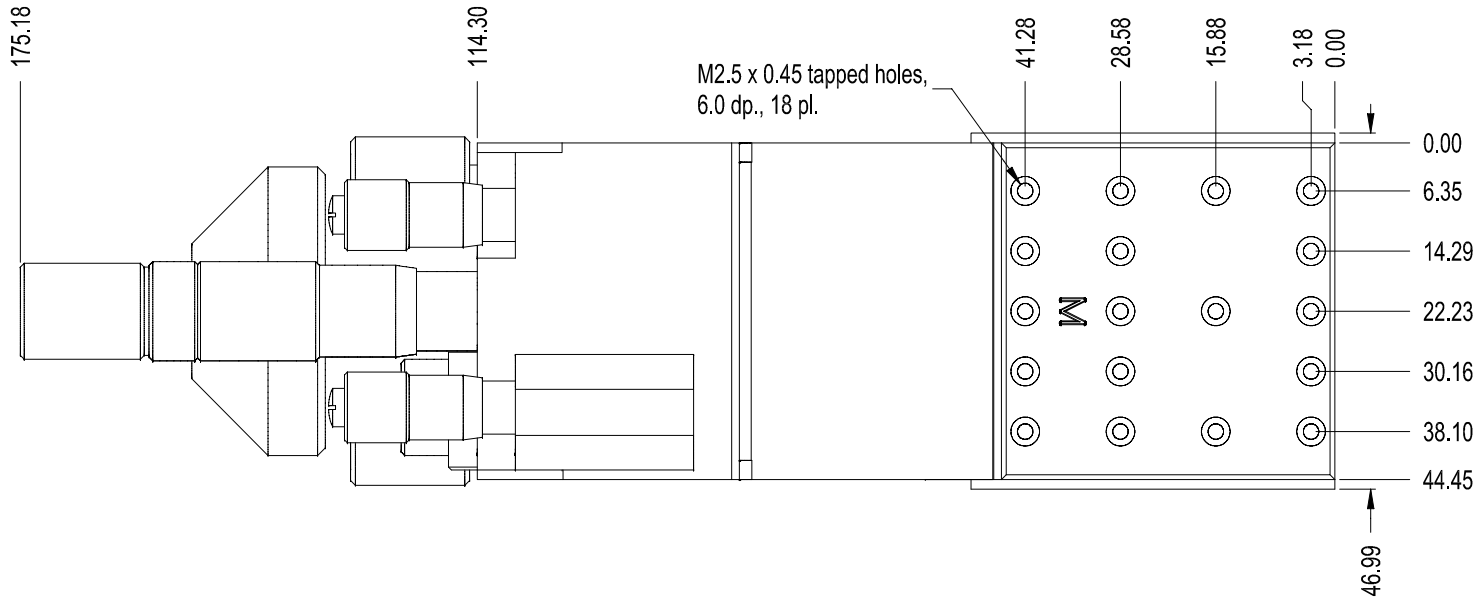

LUMINOS INDUSTRIES LTD			
15000 XYZYP Positioner (manual) Outline Top & Bottom (Z-Axis stage only)			
SIZE A	VIEW	DWG NO. PT048513A	REV A
SCALE 1	FILE PT0485A.ckd	SHEET 2/3	

Material: _____
 Finish: _____ Tolerance: _____

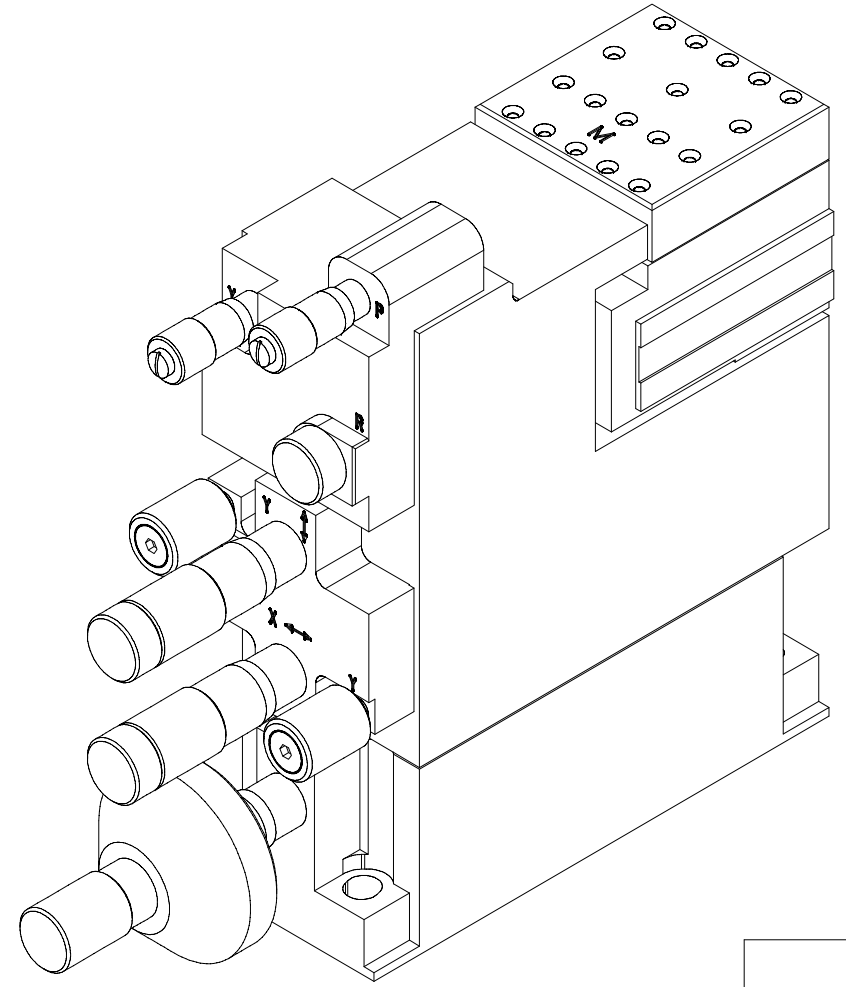
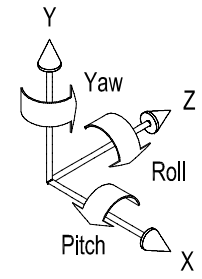

LUMINOS INDUSTRIES LTD				
I5000 XYZYP Positioner (manual) - Perspective View				
SIZE A	VIEW	DWG NO.	PT048513A	REV A
SCALE 0.75	FILE	PT0485A.ckd	SHEET 3/3	

Material:	
Finish:	Tolerance:

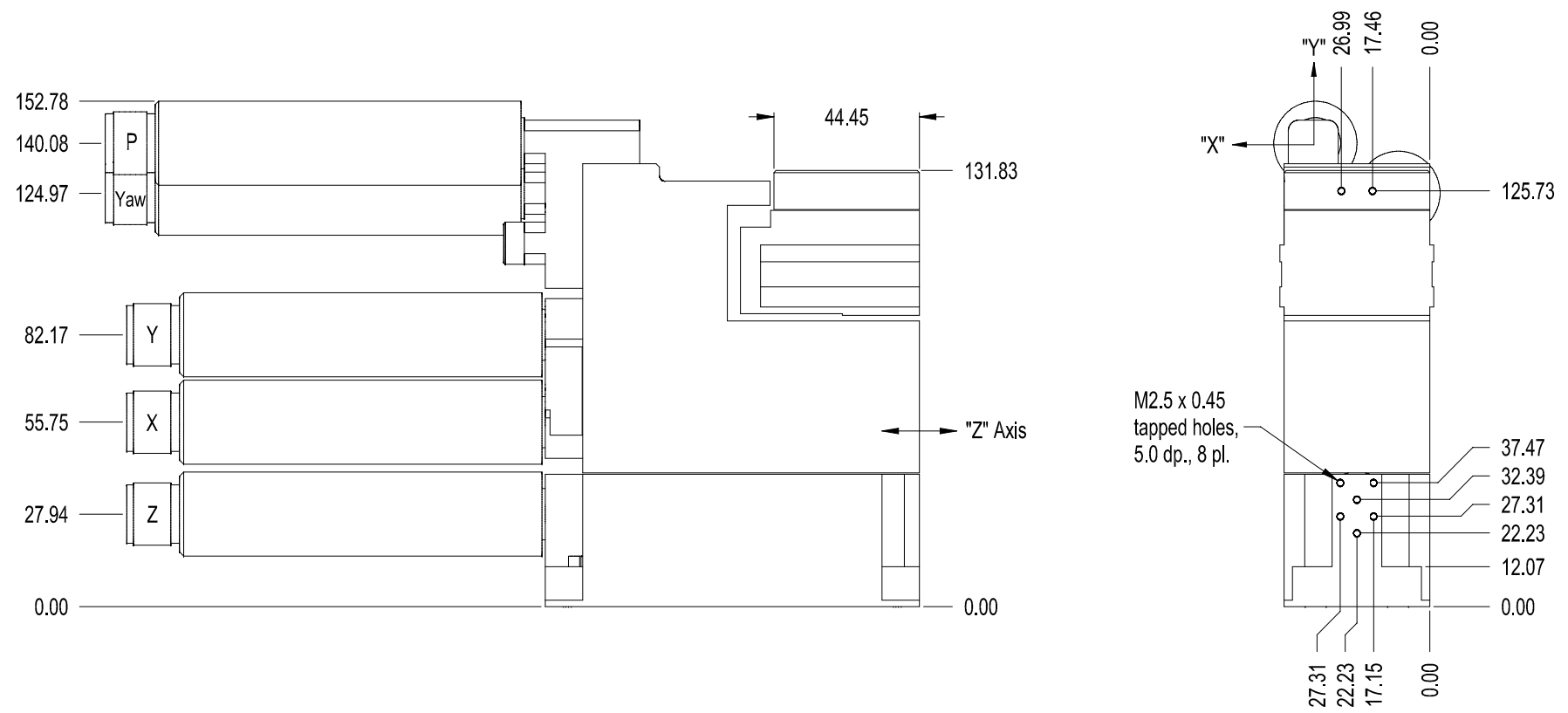

NOTE: Stage is shown in mid-position of travel
 Z-Axis travel: $\pm 6.35\text{mm}$ (0.250")
 X&Y Axis travel: $\pm 1.02\text{mm}$ (0.040") coarse adjustment,
 $\pm 250\mu\text{m}$ (0.010") fine adjustment
 Yaw & Pitch travel: $\pm 1.5^\circ$ each axis

LUMINOS INDUSTRIES LTD				
I5000 XYZYP Positioner (stepper motor) - Front & End Outline				
SIZE A	VIEW	DWG NO.	PT048514A	REV A
SCALE 0.5	FILE	PT0485A.ckd	SHEET 1/3	

Material:	
Finish:	Tolerance:

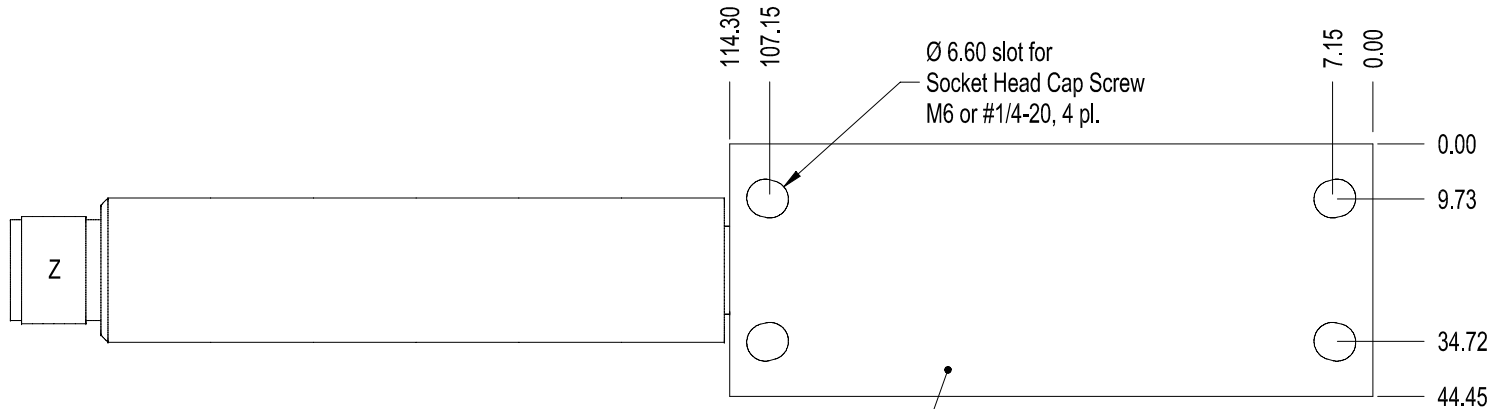
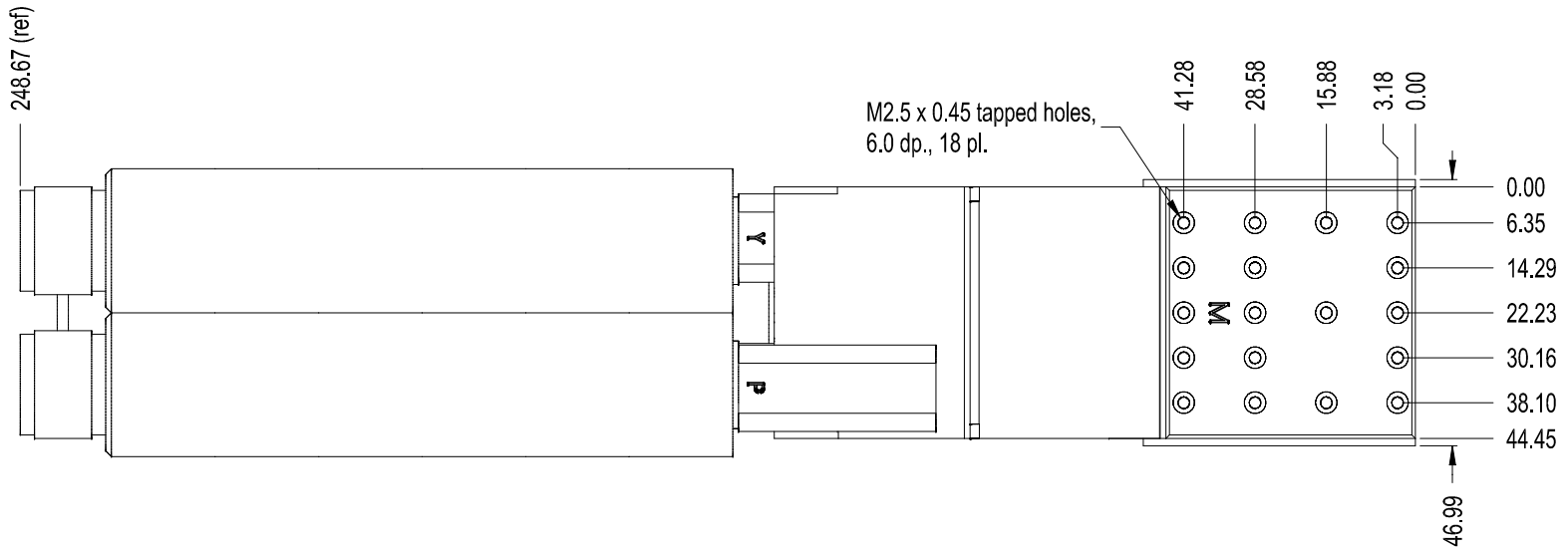

Bottom outline - Z Axis stage only

LUMINOS INDUSTRIES LTD

I5000 XYZYP Positioner (stepper motor)
Outline Top & Bottom (Z-Axis stage only)

Material:
Finish: Tolerance:

SIZE A	VIEW	DWG NO.	PT048514A	REV A
SCALE 0.75	FILE	PT0485A.ckd	SHEET 2/3	

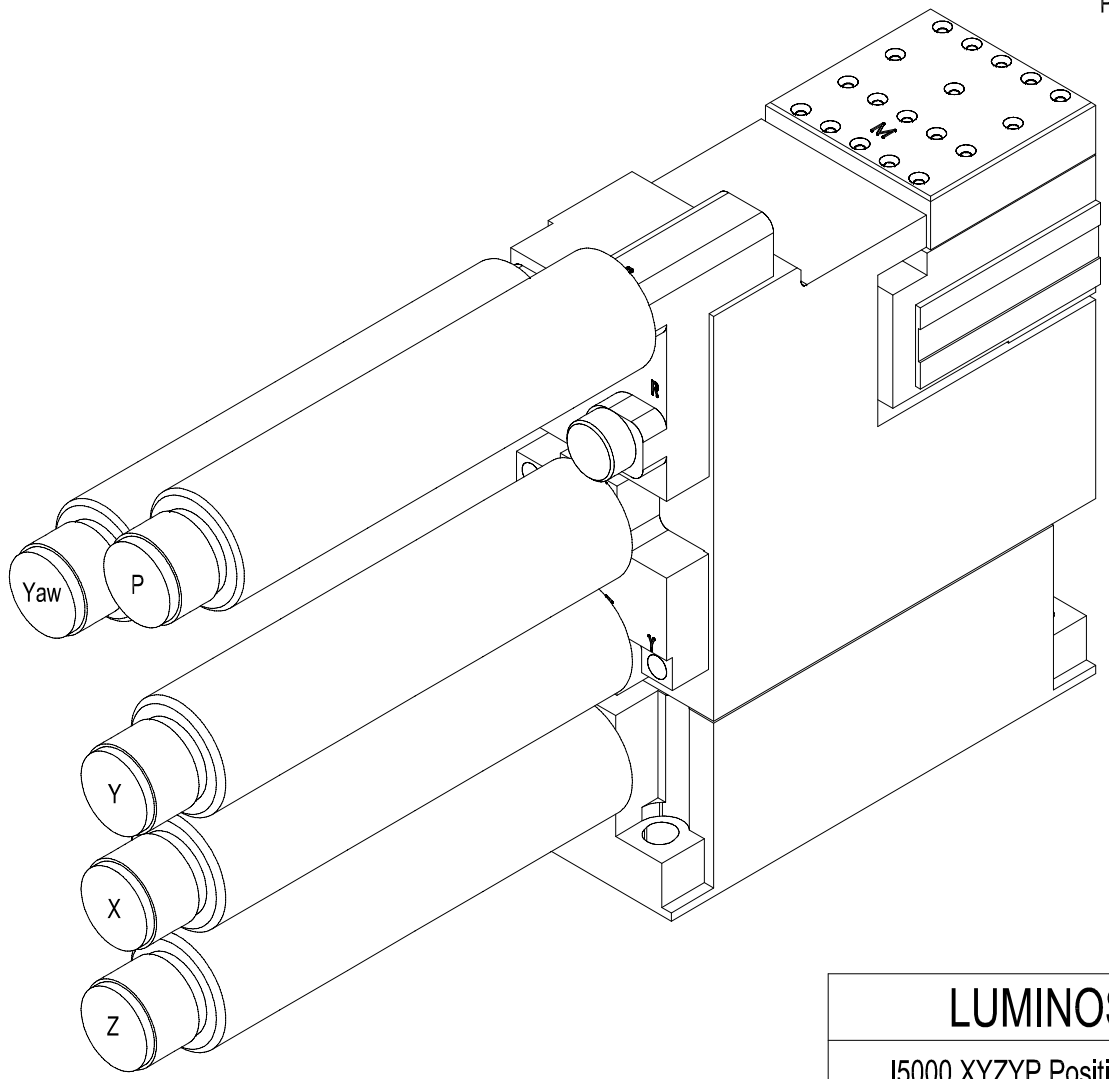
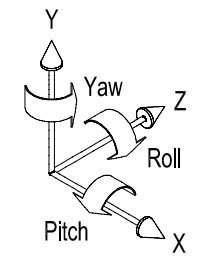

LUMINOS INDUSTRIES LTD			
1500 XYZYP Positioner (stepper motor) - Perspective View			
SIZE A	VIEW	DWG NO. PT048514A	REV A
SCALE 0.7	FILE PT0485A.ckd	SHEET 3/3	

Material:	
Finish:	Tolerance: